

## Quad High Amp Module



### Introduction

The E-Plex 407QHM is a six channel DC power distribution module capable of handling loads of up to 15A per channel or 50A total. Four channels are internally paralleled in sets of two in order to support higher amperage loads. Each channel can be utilized as either inputs, outputs, or a combination of both.

The 407QHM incorporates thermal, short circuit, and programmable overload protection in order to safeguard the module against very rare or severe conditions. Local electronic override capabilities allow independent operation of the device loads.

In addition, the 407QHM design allows for the ability to utilize up to two channels as dimmer circuits, providing a flexible solution for lighting without requiring additional external dimming hardware.

### Key Features

- 6 channels with outputs capable to 15 amps each (50 amps total).
- 4 channels internally paralleled to support higher amperage load.
- 2 channels with PWM dimming capabilities.
- Reverse battery protected.
- Status LED's for each channel.
- Thermal, short circuit, and programmable overload protection.
- Local electronic override capabilities.
- Designed for motor loads.
- LEN value 2.

### Design Specifications

- Shock: Mil Std 202 Method 213 test condition 1.
- Vibration: Tested to Lloyds Register Approval Vibration Test 2.
- Transient voltage suppression: EN6100-6-1.
- Moisture resistance: IP66.
- PCB characteristics: UL94V-0.
- Power distribution: UL 1077 compliant (except high-voltage dielectric test).
- Ignition protection: UL 1500 compliant.
- Salt spray: Tested to Lloyds Register Approval Salt Spray Test.
- Operating Temperature: -40°C to 60°C.
- Storage Temperature: -40°C to 85°C.
- Operating Humidity: 0% to 100% (condensing).
- Weight: 1.34 lb (610g).

## Electrical Specifications

Description	Minimum	Nominal	Maximum	Absolute Maximum (Surge)
Voltage	7 VDC	12/24 VDC	32 VDC	45 VDC
Current, Total	0.025 A	30 A	50 A <sup>1</sup>	160 A <sup>2</sup>
Current, per channel continuous	0	12 A	15 A	80 A <sup>4</sup>
Current, per channel intermittent duty <sup>3</sup>	0	–	20 A	80 A <sup>4</sup>
Inrush capable per channel	–	–	80 A	80 A <sup>4</sup>
Input low threshold <sup>9</sup>	0 V	–	3.5 V	–
Input high threshold <sup>9</sup>	4.5 V	–	32 V	–
Lead inductance	0	–	100 $\mu$ H <sup>8</sup>	–
Load Inductance <sup>7</sup>	0	–	20 mH	–
PWM Frequency <sup>6</sup>	0 Hz	122 Hz	–	–
Output Impedance <sup>5</sup>	10 m $\Omega$	12 m $\Omega$	14 m $\Omega$	

The supply to the module should be protected by a fuse or circuit breaker, 50A maximum.

## Mounting Instructions

Screw assembly to a flat mounting surface in 2 places, as shown in the illustration.

Imperial (English) fasteners: Use #10 size screw, #10 split lock washer, #10 washer. Torque to 20~22 in-lb. Do not exceed this torque as it could cause damage to the electronics.

Metric fasteners: Use M5 size screw, M5 split lock washer and M5 washer. Torque to 250~280 N-cm. Do not exceed this torque as it could cause damage to the electronics.

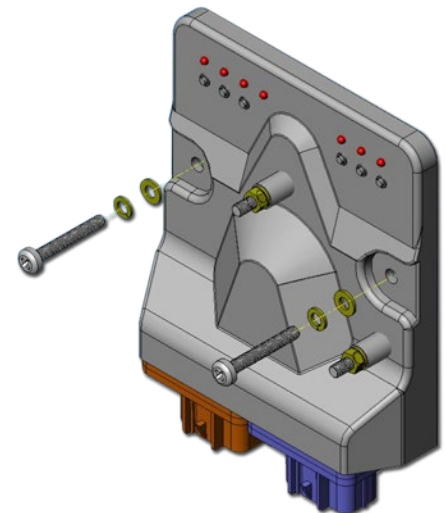

### NOTES:

1. De-rate max current by 0.2 A per °C above ambient, 25°C.
2. Measured at 8.3 ms single half sine wave. (JEDEC Method).
3. Duty cycle at 1 minute on time, 5 minutes off. Trip delay must be set to maximum rating.
4. Single pulse only.
5. Measured at 10 A load.
6. PWM not recommended for motor loads unless factory authorized.
7. For load resistance greater than 2 ohms load inductance is unlimited.
8. Specified as 50 feet of 2 AWG (43 mm<sup>2</sup>) wires with a 6 inch diameter spool for both power and ground.
9. For a channel configured as an input this specifies the turn-on/off threshold impedance @ 50K.

## Trip Speed Characteristics

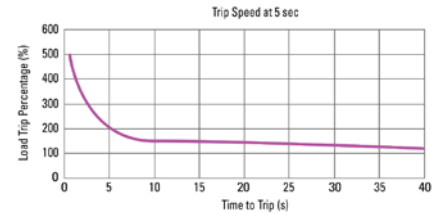
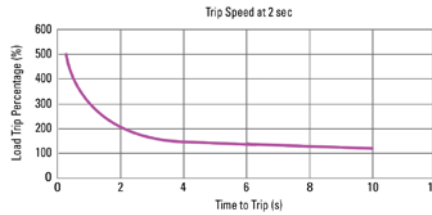
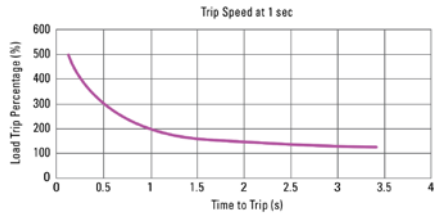

## Wiring Specifications

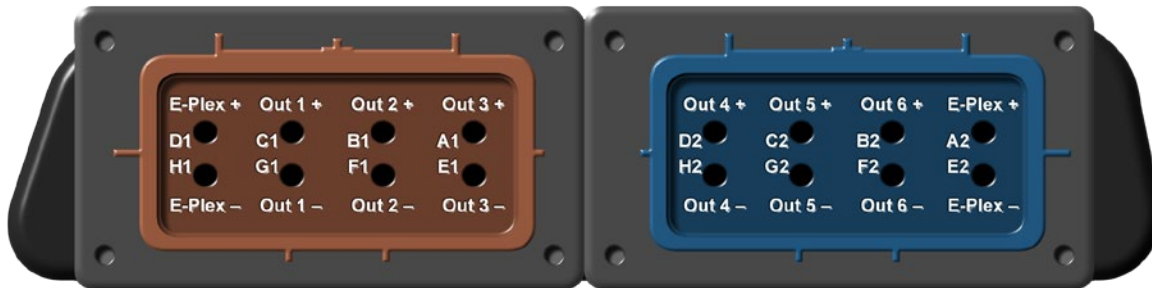

	Pin #		Pin Description		
	Pin #	Pin Description	Pin #	Pin Description	
PWM Capable	A1	Solid State Output 3	D2	Solid State Output 4	Paralleled Channels
	E1	Output 3 Return	H2	Output 4 Return	
	B1	Solid State Output 2	C2	Solid State Output 5	
	F1	Output 2 Return	G2	Output 5 Return	
	C1	Solid State Output 1	B2	Solid State Output 6	
	G1	Output 1 Return	F2	Output 6 Return	
	D1	E-Plex Data Bus +	A2	E-Plex Data Bus +	
	H1	E-Plex Data Bus -	E2	E-Plex Data Bus -	
	M5-T1	Battery Power	M5-T2	Battery Return	

Outputs and Returns: 0 to 15A, 7-32VDC.

The first two outputs (C1, B1) are PWM capable and may be used to dim lighting loads.

Internally Paralleled Channels: Outputs 3 & 4 (A1, D2), Outputs 5 & 6 (C2, B2).

Battery Power (+): 0.025A to 50A, 7-32VDC.

Status LEDs:

ON - Channels 1-6 indicates Load ON, E-Plex channel indicates module responding.

OFF - Channels 1-6 indicates Load OFF, E-Plex channel indicates module not responding.<sup>10</sup>

BLINKING - Channels 1-6 indicates Load FAULT, E-Plex channel indicates module responding.

Power / Battery Connections: Must be fused. Maximum wire size should be sized based on upstream fuse. When connecting the power source to the power studs on the module, torque the M5 hex nuts should be torqued to 20~22 in lb or 250~280 n-m after installing the battery terminals to the studs. Failure to properly torque hex nuts may result in intermittent operation due to terminals loosening over time. Note: External surge suppression is required when the module battery supply cable is longer than 50' (25' for any 2 outputs that are paralleled).

Reversed Battery Conditions: The loads will turn on, but no damage will occur to the module if disconnected within 1 minute (Under nominal operating load conditions).

## Pin Specifications

Cable Range AWG (mm <sup>2</sup> )		Female Terminal	Terminal Insulation Range	Seal Insulation Range	Seal P/N
18-16	(1.0-0.75 mm <sup>2</sup> )	15304716	1.70-2.25 mm	1.20-1.85 mm	15366063
				1.85-2.25 mm	15356064
16-12	(2.50-1.50 mm <sup>2</sup> )	15304717	2.20-3.00 mm	2.09-2.66 mm	15366061
				2.70-3.2 mm	15336674

## Typical Wiring Diagram

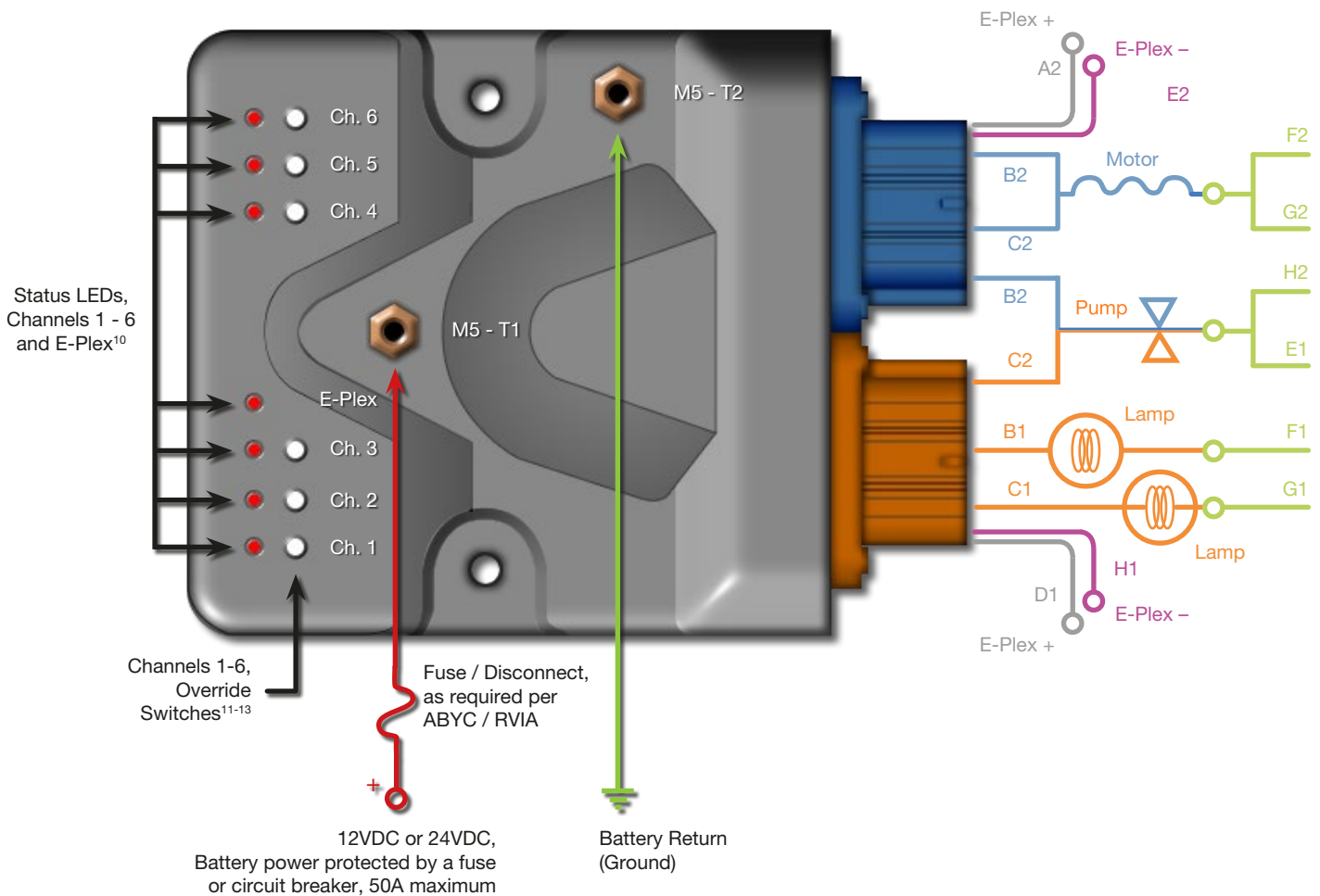

### NOTES:

- LED will be off if system is not functioning or present, however, modules in the system may still be responding.
- Manual override switches are meant to be used as a local electronic manual override for emergency situations only.
- Load activation function for switches 1 thru 6 are defined in E-Logic as either toggle or momentary operation.
- Manual override for paralleled channels 3 & 4 , 5 & 6 will still operate independently, both switches must be pressed to support required load.

## Dimensional Diagram

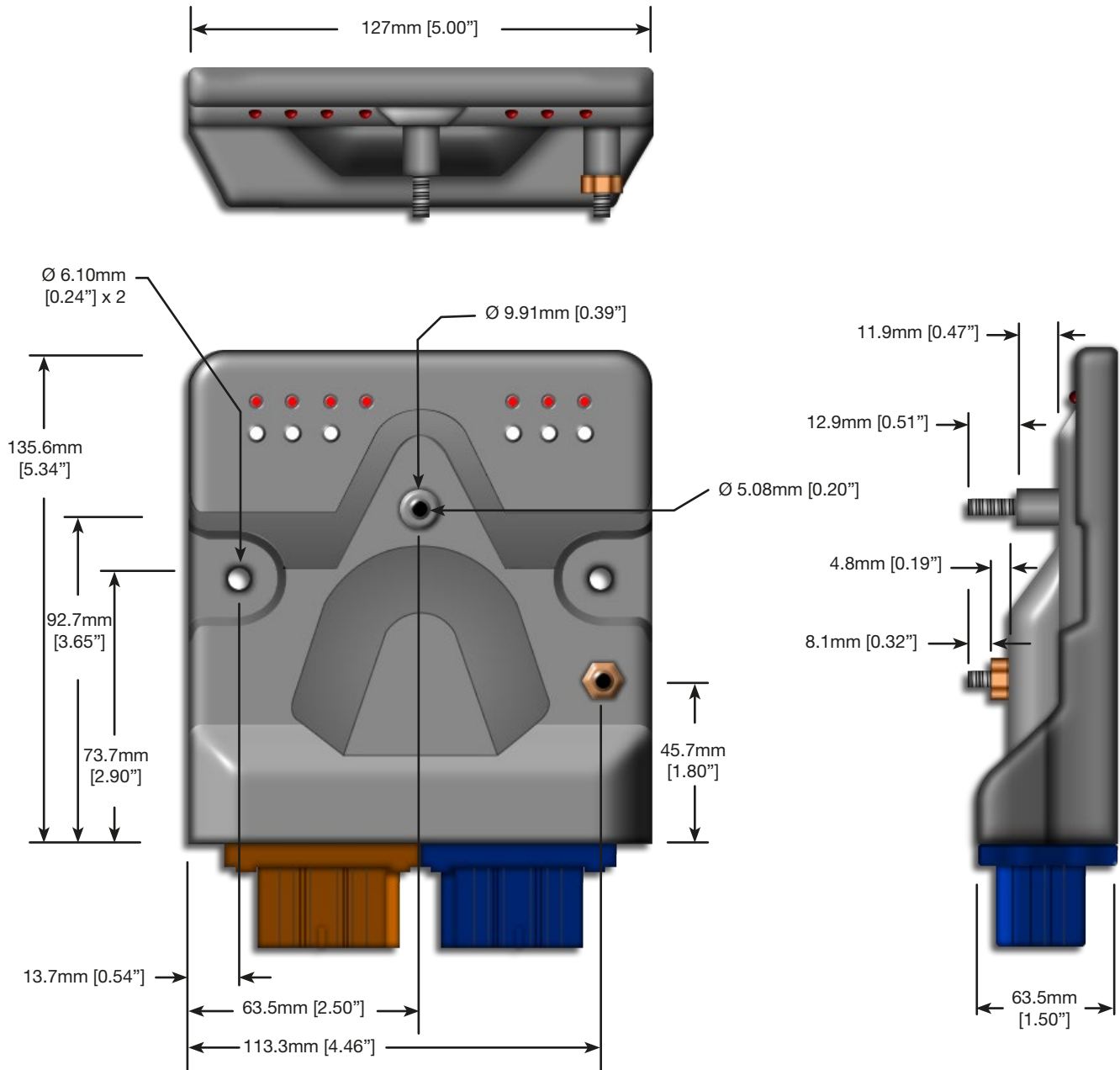

## Mechanical Specifications

### Connectors:

J1 - Brown: Mates to Delphi P/N 15317308

J2 - Blue: Mates to Delphi P/N 15317304

### Cavity Plug:

Delphi P/N 12059168

### Power Stud Connections:

M5 nickel plated brass

## Ordering Information

Description	E-Plex Part Number
407QHM Series - Quad High Amp Module	EP-SW-IO-4CH-407QHM



52 – 54 Riverside, Sir Thomas Longley Road, Medway City Estate, Rochester, Kent ME2 4DP  
tel: +44 (0)1634 711622 fax: +44 (0)1634 290773

email: [sales@e-plex.co](mailto:sales@e-plex.co)  
web: [www.e-plex.co](http://www.e-plex.co)

Important Notice: E-Plex Ltd. (E-Plex) reserves the right to make changes to or discontinue any product or service identified in this publication without notice. E-Plex advises its customers to obtain the latest version of the relevant information to verify, before placing any orders, that the information being relied upon is current. E-Plex assumes no responsibility for infringement of patents or rights of others based on E-Plex applications assistance or product specifications since E-Plex does not possess full access concerning the use or application of customers' products. E-Plex also assumes no responsibility for customers' product designs.